

STC Actuated Valves



Precision Engineered

Fine Quality



Advanced Design

Excellent Prices



connects fluid power to industrial automation™

Website: StcValve.com

STC PNEUMATIC ACTUATED VALVES

TABLE OF CONTENTS:

ACTUATOR KEY FEATURES.....	2
STC AIR ACTUATED VALVE NUMBERING SYSTEM & ACTUATOR MOUNT BALL VALVE SPECIFICAITONS.....	3
PNEUMATIC ACTUATOR SPECIFICATIONS & PNEUMATIC ACTUATOR AND VALVE MODEL SELECTION.....	4
PNEUMATIC ACTUATOR MOUNTING CONNECTION AND DIMENSIONS.....	5
PNEUMATIC ACTUATOR OUTPUT TORQUE	6
PNEUMATIC ACTUATOR MATERIALS OF CONSTRUCITONS.....	7
PNEUMATIC ACTUATOR INTERNAL STRUCTURE.....	8
PNEUMATIC ACTUATOR PRINCIPLE OF OPEATION	9

ACTUATOR KEY FEATURES:

1. Full conformance to the specifications of: ISO5211, DIN3337, VDI/VDE3845, NAMUR.
2. The extruded high strength aluminum bodies are precision honed and hard anodized yielding an internal bore surface that can provide low coefficient of friction, smooth performance and a long service life.
3. All acting surfaces are fitted with high quality bearings, resulting in low friction, quite and high cycle life.
4. The two independent external travel stop adjustment bolts can easily and precisely adjust up to $\pm 5^\circ$ at both open and closed directions.
5. Multifunction position indicator with NAMUR standard is convenient for mounting accessories.
6. Pre-compressed load springs are convenient for safe mounting and disassemble operations.
7. Die-casted aluminum pistons and end caps are high strength and light weight.
8. Optional Viton and Silicone seals are available for low and high temperature applications.

STC Air Actuated Valve Numbering System

Ordering Part No. =
(eg. **KS-1/2**)

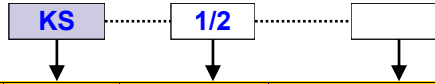

		AIR ACTUATED VALVE	Model	Port Size (NPT)	Options	
	Ball Valve 316 Stainless Steel	Single Acting (Spring Return)	KS	1/2"	VALVE CONNECTION OPTIONS: BLANK= NPT CONNECTION F= FLANGE CONNECTION W= BUTT WELD CONNECTOR	
				3/4"		
				1"		
				1 1/4"		
				1 1/2"		
		Double Acting (Air Return)	KD	2"		ACTUATOR SEAL OPTIONS: BLANK= NBR S= ACTUATOR WITH HIGH TEMP SILICONE SEAL V= ACTUATOR WITH HIGH TEMP VITON SEAL
				2 1/2"		
				3"		
				4"		

ACTUATOR MOUNT BALL VALVE SPECIFICATIONS

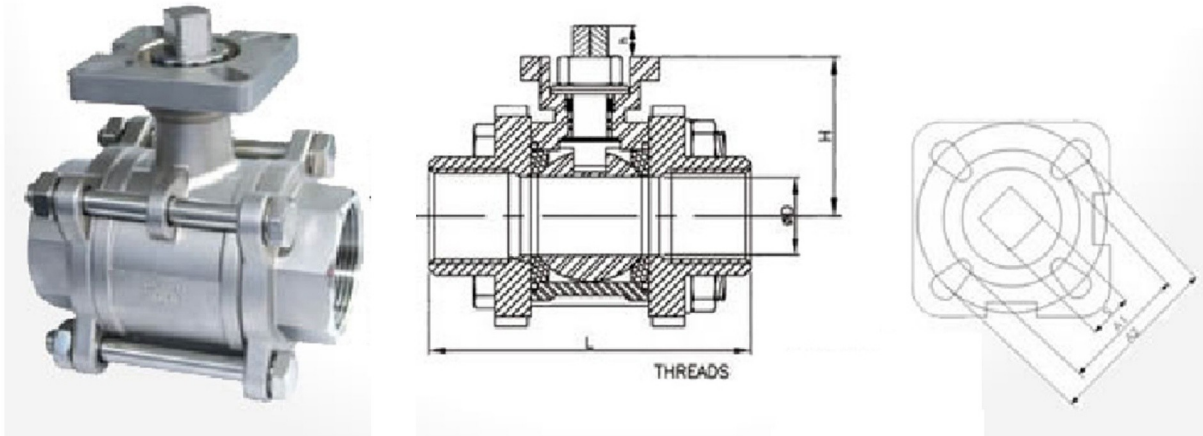

Model: V3 Specifications	
Operating Pressure	1/2" to 2": 1000 PSI @ 100°F WOG 2 1/2" to 3" : 800 PSI @ 100°F WOG
Operating Temperature	-60 to 450°F*
Port	Full Port
Port Connection	End Connections: FNPT
Mounting standard	DIN 3203-M3, ISO 5211 MOUNTING PAD, ISO5211 PLATFORM

Main Parts and Materials			
No	Part Name	Material	Qty
1	SEAT	PTFE	2
2	BALL	SS316	1
3	JOINT GASKET	PTFE	1
4	CAP	SS316	1
5	BODY, BODY CONNECTOR	SS316/CF8M	1, 2
6	STEM	SS316	1
7	THRUST WASHER	PTFE	1
8	STEM PACKING	PTFE	1
9	GLAND NUT	SS304	1
10	STEM WASHER	SS304	1
11	STEM NUT	SS304	1
14	BODY CONNECTOR BOLT	SS304	4
15	BODY CONNECTOR NUT & WASHER	SS304	4

Dimensions (mm)							
SIZE						ISO05211	
	NPT	D	L	H	h	S	A1 A2
1/2"	15	75	38	9	9	F03	F04
3/4"	20	80	47	9	9	F03	F04
1"	25	90	57.2	11	11	F04	F05
1 1/4"	32	110	62.5	11	11	F04	f05
1 1/2"	38	120	77.5	14	14	F05	F07
2"	50	140	86.5	14	14	F05	F07
2 1/2"	65	162	108	17	17	F07	F10
3"	80	184	115	17	17	F07	F10
4"	100	228	141	22	22	F07	F10

PNEUMATIC ACTUATOR SPECIFICATIONS

STANDARD	ISO5211, DIN3337, VDI/VDE3845, NAMUR
Maximum Actuator Pressure	116 psig (8.0 bar)
Temperature Range	Standard -4 to 176°F (-20 to 80°C) High Temperature 5 to 302°F (-15 to 150°C) Low Temperature -40 to 176°F (-40 to 80°C)
Materials	Housing, End Cap Aluminum O-Rings: standard: Buna N, Options: fluorocarbon FKM, or silicone Mounting Bracket 316 stainless steel

PNEUMATIC ACTUATOR AND VALVE MODEL SELECTION

316SS 3 PIECE BALL VALVE SIZE	ACTUATOR SIZE (MM)	MOUNTING STD. ISO5211	Double Acting Torque (in-Lbs)	AIR PRES-SURE	MODEL NO.					
					Female NPT		Flange type		Butt weld type	
					SINGLE ACTING	DOUBLE ACTING	SINGLE ACTING	DOUBLE ACTING	SINGLE ACTING	DOUBLE ACTING
1/4"	32	F03-F04	87	100 PSI	KS-1/4	KD-1/4	KS-1/4F	KD-1/4F	KS-1/4W	KD-1/4W
3/8"	32	F03-F04	87	100 PSI	KS-3/8	KD-3/8	KS-3/8F	KD-3/8F	KS-3/8W	KD-3/8W
1/2"	32	F03-F04	87	100 PSI	KS-1/2	KD-1/2	KS-1/2F	KD-1/2F	KS-1/2W	KD-1/2W
3/4"	32	F03-F04	87	100 PSI	KS-3/4	KD-3/4	KS-3/4F	KD-3/4F	KS-3/4W	KD-3/4W
1"	52	F04-F05	226	100 PSI	KS-1	KD-1	KS-1F	KD-1F	KS-1W	KD-1W
1-1/4"	52	F04-F05	226	100 PSI	KS-1 1/4	KD-1 1/4	KS-1 1/4F	KD-1 1/4F	KS-1 1/4W	KD-1 1/4W
1-1/2"	63	F05-F07	405	100 PSI	KS-1 1/2	KD-1 1/2	KS-1 1/2F	KD-1 1/2F	KS-1 1/2W	KD-1 1/2W
2"	75	F05-F07	737	100 PSI	KS-2	KD-2	KS-2F	KD-2F	KS-2W	KD-2W
2-1/2"	85	F07-F10	1072	100 PSI	KS-2 1/2	KD-2 1/2	KS-2 1/2F	KD-2 1/2F	KS-2 1/2W	KD-2 1/2W
3"	92	F07-F10	1376	100 PSI	KS-3	KD-3	KS-3F	KD-3F	KS-3W	KD-3W
4"	105	F07-F10	2230	100 PSI	KS-4	KD-4	KS-4F	KD-4F	KS-4W	KD-4W

PNEUMATIC ACTUATOR MOUNTING CONNECTION AND DIMENSIONS

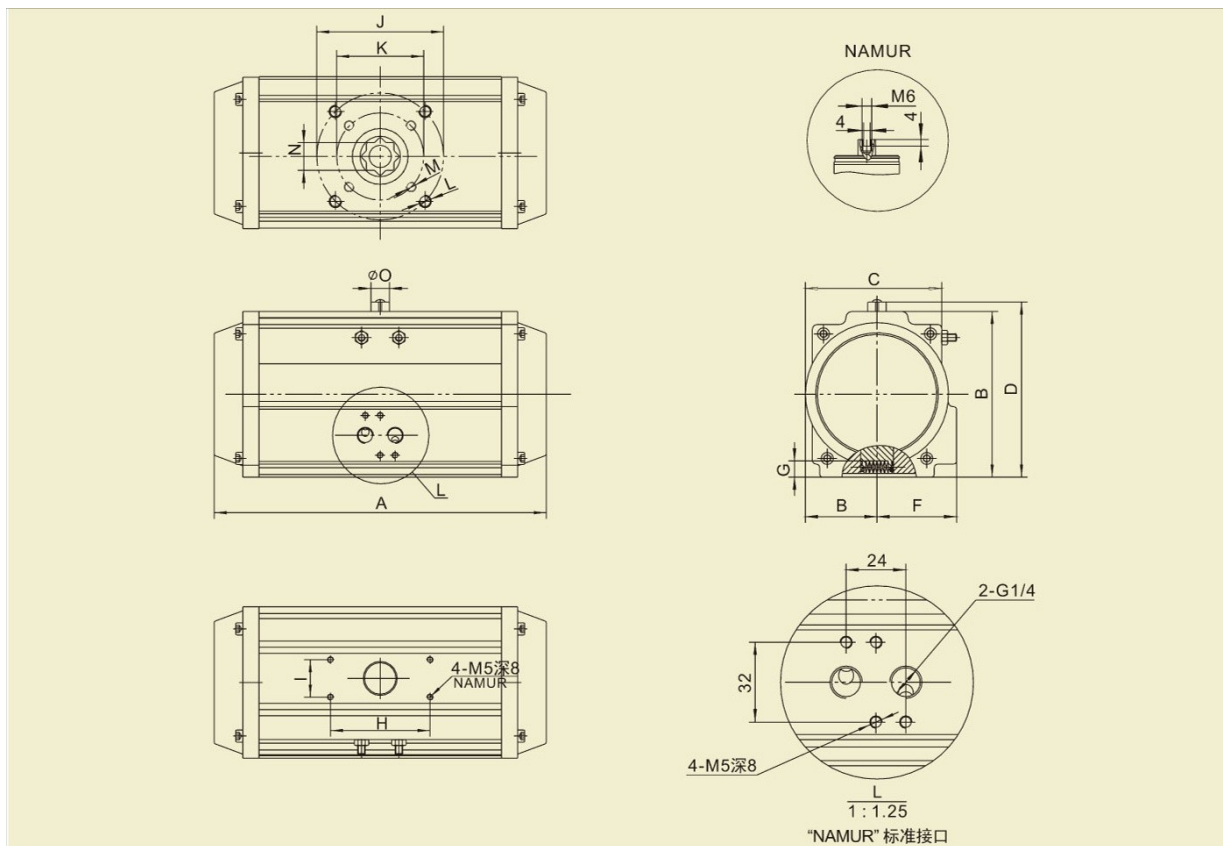

MODEL	A	B	C	D	E	F	G	H	I	J	K	L	M	N	O	A120	A180	AIR CON- NECTION
32	110	45	45	65	22.5	23	12	50	25		F03/36		M5X5	9				G1/8
52	143	72	55	92	30	41	14	80	30	F05/50	F03/36	M6X8	M5X8	11	40	158	200	G1/4
63	190	88	69	108	35	45	18	90	30	F07/70	F05/50	M8X13	M6X10	14	40	184	233	G1/4
75	207	99.5	100.5	119.5	38.5	52.5	20.5	80	30	F07/70	F05/50	M8X10	M6X8	14	40	203	243	G1/4
85	213	109	88	129	46	52.5	21	80	30	F07/70	F05/50	M8X13	M6X10	17	40	221	280	G1/4
92	258	117	98.5	137	50	61	21	80	30	F07/70	F05/50	M8X12	M6X10	17	40	280	374	G1/4
105	267	133	109	153	57	64	26	80	30	F10/102	F07/70	M10X13	M8X10	22	40	304	388	G1/4
125	340	155	120.5	175	67.5	70	27.5	80	30	F10/102	F07/70	M10X16	M8X13	22	65	365	470	G1/4
140	414	171.5	132	191.5	75	76	32	80	30	F12/125	F10/102	M12X20	M10X15	27	65	442	568	G1/4

NOTE: A120 and A180 represent the acting length of the 120° rotation travel and 180° rotation travel, respectively.

DOUBLE ACTING PNEUMATIC ACTUATOR TORQUE OUTPUT (in-Lbs)								
DA ACTUATOR SIZE	AIR PRESSURE (PSI)							
	40	50	60	70	80	90	100	115
32	34	43	55	64	71	82	87	101
52	85	110	133	156	179	203	226	261
63	154	196	238	280	321	363	405	458
75	284	360	435	511	586	661	737	850
85	408	518	629	740	851	962	1072	1238
92	527	668	810	951	1093	1234	1376	1588
105	858	1087	1315	1544	1773	2000	2230	2573
125	1409	1783	2157	2532	2906	3280	3654	4216
140	2209	2511	3013	3515	4018	4513	5015	5772

SINGLE ACTING PNEUMATIC ACTUATOR OUTPUT TORQUE (UNIT Nm)													
AIR PRESSURE (BAR)		3		4		5		6		7		Spring Stroke	
ACTUATOR SIZE	# OF SPRING	0°	90°	0°	90°	0°	90°	0°	90°	0°	90°	0°	90°
		52	5	8.48	6.28	12.64	10.44						
6	7.68		4.98	11.84	9.14							4.8	7.5
7	6.98		3.78	11.14	7.94							5.5	8.7
8				10.34	6.74	14.5	10.9					6.3	9.9
9				9.54	5.44	13.7	9.6					7.1	11.2
10				8.74	4.24	12.9	8.4	17.06	12.56			7.9	12.4
12						12.1	7.1	16.26	11.26	20.42	15.42	8.7	13.7
63	5	15	11.2	22.3	18.5	29.6	25.8					7	10.8
	6	13.5	9	20.8	16.3	28.1	23.7					8.5	12.9
	7	12	6.9	19.4	14.2	26.7	21.5					9.9	15.1
	8			18	12	25.3	19.3	32.6	26.6			11.3	17.3
	9			16.5	9.9	23.9	17.2	31.2	24.5			12.7	19.4
	10			15.3	7.7	22.6	15	29.9	22.3	37.2	29.6	14	21.6
	12			13.8	5.6	21.1	12.9	28.4	20.2	35.7	27.5	15.5	23.7
75	5	23.4	17.8	35.1	29.5							11.9	17.5
	6	21.1	14.3	32.8	26							14.2	21
	7	18.7	10.8	30.4	22.5							16.6	24.5
	8			28	19	39.8	30.8					19	28
	9			25.7	15.5	37.5	27.3					21.3	31.5
	10			23.3	12	35.1	23.8	46.8	35.5	58.6	47.3	23.7	35
	12					32.7	20.3	44.4	32	56.2	43.8	26.1	38.5
83	5	30.9	23.8	46.1	38.9							14.5	21.7
	6	28.1	19.5	43.3	34.6							17.4	26
	7	25.2	15.1	40.3	30.2							20.3	30.4
	8			37.4	25.9	52.6	41.1					23.2	34.7
	9			34.5	21.5	49.7	36.7					26.1	39.1
	10			31.6	17.2	46.8	32.4	62	47.6	77.1	62.7	29	43.4
	12					43.9	28.1	59.1	43.3	74.2	58.4	31.9	47.7
92	5	50.3	37.8	75.6	63							25.5	38
	6	45.2	30.2	70.4	55.4							30.6	45.6
	7	40.1	22.6	65.3	47.8							35.7	53.2
	8			60.2	40.2	85.5	65.5					40.8	60.8
	9			55.1	32.7	80.4	57.9					45.9	68.4
	10			50	25	75.3	50.3	100.6	75.6	125.8	100.8	51	76
	12					70.2	42.7	95.5	68	120.7	93.2	56.1	83.6
105	5	68.6	52	103.6	87							33.2	49.8
	6	61.9	42	96.9	77							39.9	59.8
	7	55.3	32.1	90.3	67.1							46.5	69.7
	8			83.7	57.1	116.6	90					53.1	79.7
	9			77	47.4	109.9	80.3					59.8	89.4
	10			70.4	37.2	103.3	70.1	137.3	104	171.2	138	66.4	99.6
	12					96.7	60.1	130.6	94	164.6	128	73	109.6
125	5	115.5	88	173.8	146.3							59.4	86.9
	6	103.6	70.6	161.9	128.9							71.3	104.3
	7	91.8	53.5	150.1	111.6							83.1	121.6
	8			138.2	94.2	196.5	152.5					65	139
	9			126.3	76.8	184.6	135.1					106.9	156.4
	10			114.4	59.4	172.7	117.7	231	176			118.8	173.8
	12					160.9	100.4	219.2	158.7	277.5	217	130.6	191.1
					149	83	207.3	141.3	265.6	199.6	142.5	208.5	

PNEUMATIC ACTUATOR MATERIALS OF CONSTRUCTION

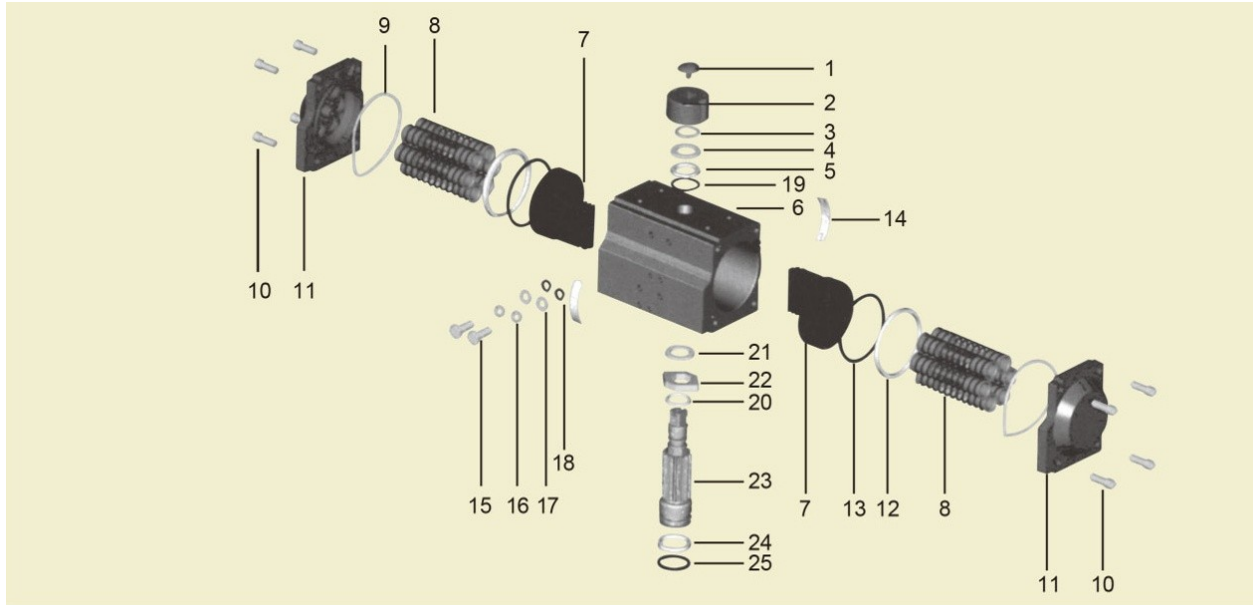

NO.	NAME	QTY	MATERIAL	FINISH	OPTION
1	INDICATOR SCREW	1	PLASTIC		
2	INDICATOR	1	PLASTIC		
3	SPRING CLIP	1	STAINLESS STEEL		
4	WASHER	1	STAINLESS STEEL		
5	OUTSIDE WASHER	1	PFTE		
6	BODY	1	EXTRUDED ALUMINUM	HARD ANODIZED	
7	PISTON	2	EXTRUDED ALUMINUM	ANODIZED/ZINC GALVANIZED	STAINLESS STEEL
8	SPRING-INTEGRATED	*	SPRING STEEL	DIP COATING	
9	O-RING (END CAP)	2	NBR		VITON/SILICONE
10	CAP SCREW	8	STAINLESS STEEL		
11	END CAP	2	ALUMINUM ALLOY	POLYESTER POWDER PAINTED	
12	PISTON BEARING	2	ENGINEERING PLASTIC		
13	PISTON O-RING	2	NBR		VITON/SILICONE
14	PISTON GUIDE	2	ENGINEERING PLASTIC		
15	ADJUSTMENT SCREW	2	STAINLESS STEEL		
16	ADJUST SCREW NUT	2	STAINLESS STEEL		
17	AJUSTMENT SCREW WASHER	2	STAINLESS STEEL		
18	AJUSTMENT SCREW O-RING	2	NBR		VITON/SILICONE
19	PINION TOP O-RING	1	NBR		VITON/SILICONE
20	PINION TOP BEARING	1	ENGINEERING PLASATIC		
21	INSIDE WASHER	1	PTFE		
22	CAM	1	ALLOY STEEL		
23	PINION	1	ALLOY STEEL	NICKEL PLATED	STAINLESS STEEL
24	PINION BOTTOM O-RING	1	ENGINEERING PLASTIC		
25	PINION BOTTOM BEARING	1	NBR		VITON/SILICONE

PNEUMATIC ACTUATOR INTERNAL STRUCTURE

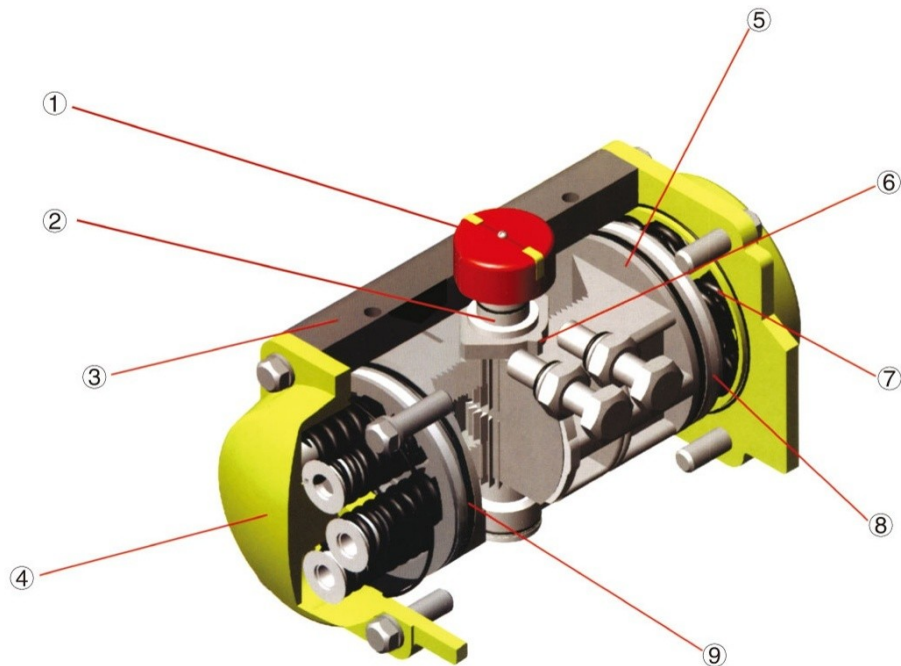

1. Indicator: Position indicator with NAMUR standard is convenient for mounting accessories such as Limit Switch box positioned etc.
2. Pinion: The pinion is high precision and integrative, made from nickel plated alloy steel, full conform to the latest standards of ISO5211, DIN3337, VDI/VDE3845, NAMUR. The dimensions and the stainless steel option can be customized for specific applications.
3. Actuator Body: The extruded aluminum alloy ASTM 6005 body can be treated with hard anodized, polyester powder coated, PTFE or Nickel Plated.
4. End Caps: Die-casting aluminum polyester powder coated, PTFE or Nickel-plated.
5. Pistons: The twin rack pistons are made from die-casted aluminum treated with hard anodized or made from casted steel with galvanization. Symmetric mounting position, long cycle life and fast operation, reversing rotation by simply inverting the pistons.
6. Travel Adjustment: The two independent external travel stop adjustment bolts can adjust $\pm 5^\circ$ at both open and close direction easily and precisely.
7. High performance spring: Preloaded coated springs are made from high quality material for resistant to corrosion and long service life, which can be dismantled safely and conveniently to meet different torque requirements by changing the number of springs.
8. Bearing and Guides: Made from low friction, long-life compound material, to avoid the direct contact between metals. The maintenance and replacement are easy and convenient.
9. O-rings: Standard: NBR, High and low temperature; Viton or Silicone are available as options.

PNEUMATIC ACTUATOR PRINCIPLE OF OPERATION

1. Double Acting

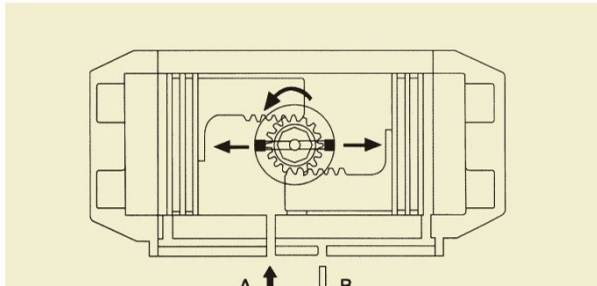

Air into Port A forces the pistons outwards, causing the pinion to turn counterclockwise while the air being exhausted from Port B.

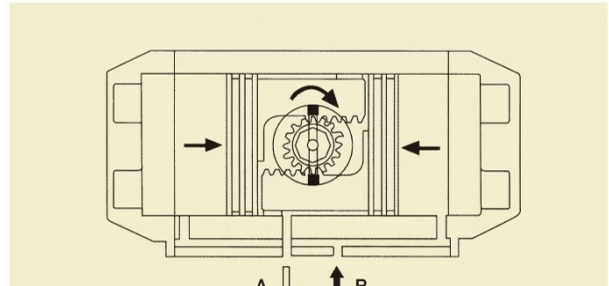

Air into Port B forces the pistons inwards, causing the pinion to turn clockwise while the air is being exhausted from Port A.

2. Single Acting:

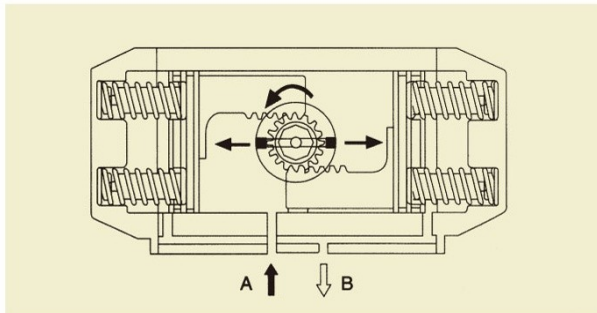

Air into Port A forces the pistons outwards, causing the springs to compress, the pinion turns counterclockwise while air is being exhausted from Port B.

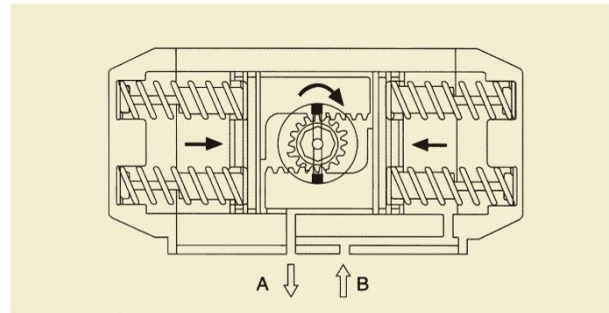

In the event of loss air pressure or power, the stored energy in the springs forces the pistons inwards, causing the pinion turns clockwise while air is being exhausted from Port A, and air to Port B can accelerate closing the valve.

PNEUMATIC ACTUATOR TORQUE DIAGRAM

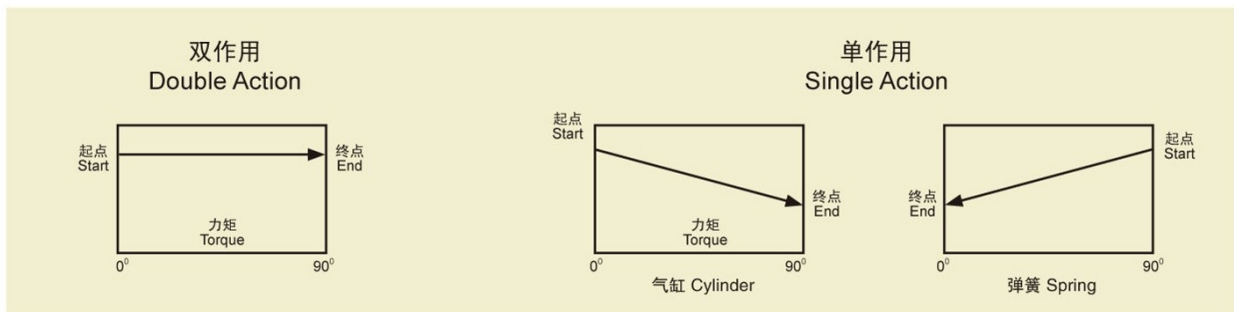

Terms and Conditions

SHIPMENTS:

All shipments are F.O.B. 892 Commercial Street, Palo Alto, CA 94303, USA. Most orders are shipped via UPS Standard Ground unless instructions accompany order. Outside the UPS zones, shipment will be made Best Way. The responsibility for goods delay, lost or damaged in transit rests with the carrier and purchaser. Purchaser may purchase shipping insurance to cover lost or damaged products caused by shipping.

RETURN OF MERCHANDISE:

No merchandise is accepted for return 30 days after delivery date. No credit allowed on merchandise shipped as ordered and returned without obtaining an authorization number IN ADVANCE. A 20% restocking charge applies to all returns, and transportation charges must be fully prepaid. We will pay **ground** transportation charges on re-sent or returned merchandise due to STC's error.

Shortages & Mis-Shipments: Any shortages or mis-shipment must be reported within 15 days.

Remittances should be sent to:

Sizto Tech Corporation

892 Commercial Street, Palo Alto, CA 94303, USA

Credit Card Payments: Visa, MasterCard, Discover, or American Express Accepted

International Customers: Advance Payment Required via Bank Wire, Cashier's Check or Approved Credit Card.

Credit Application: To establish a net 30 day account, please mail or fax three trade references with complete mailing addresses and account numbers.

LIMITED WARRANTY – IMPORTANT NOTICE TO PURCHASER:

Sizto Tech Corporation (STC) only warrants this product to be free from defects in materials and workmanship at the time of shipment. This limited warranty expires one year after delivery to the end-user. STC's entire obligation to the Purchaser for breach of this limited warranty shall be limited to replacement of the defective product or refund of the original purchase price of this product, at STC's option. Purchaser has thirty (30) days to return the goods after STC has agreed to accept the return. All freight charges on returned material shall be paid by the Purchaser. STC's limited warranty shall not apply, however, to the product that have been subjected to misuse, alteration, accident or negligence during handling or storage.

DISCLAIMER OF IMPLIED WARRANTIES:

All implied warranties, which may arise by implication of law or application of course of dealing or usage of trade, including, but not limited to, implied warranties of merchantability or fitness for a particular purpose are expressly excluded. There are no warranties, which extend beyond the description of the faced hereof. The end user is solely responsible for the suitability and fitness of this product selected for a particular application.

IMPORTANT NOTICE:

All prices are subject to change without notice. We continuously improve the products, and we reserve the right to change specifications without incurring any obligation to incorporate new factors in equipment previously sold.

Distributed By



Sizto Tech Corporation

892 Commercial Street

Palo Alto, CA 94303 USA

Tel: 650-856 8833 | Fax: 650-856 8811

Email: Sales@StcValve.com; www.StcValve.com