

Composite Fittings Specifications

A. Installation of Pipe Fittings:

1. Tighten fitting by hand, then turn it 2-3 turns with a wrench until it reaches the desired torque listed. If the fittings is not pre-coated with sealant, or is used and the sealant is not in good condition, apply Teflon sealant tape to the threads.

Recommendation of Torque for Tightening Fittings		
Fitting Thread Size	Torque, lb-ft	Torque, kgf/cm
10-32, M5 –M6	1.0 – 1.5	14 – 21
NPT1/8, R1/8	5 – 6.5	70 – 90
NPT1/4, R1/4	8.5 – 10	120 – 140
NPT3/8, R3/8	16 – 17.5	220 – 240
NPT1/2, R1/2	20 – 21.5	280 – 300

B. Installation of Tubing into Fitting:

1. Slowly push a clean and perpendicularly cut tube into the fitting until it comes to a dead stop.
2. Gently pull the tubing back until the Grip Ring or Collet of the fitting grips onto the tubing and has a good seal.

C. Removal of Tubing from Fitting:

1. Push in evenly on the two long, oval sides of the Release Button.
2. Pull out the tube while depressing the Release Button.

D. Recommended Tubing Material, Size, and Hardness Requirements:

Tubing Material	Specified Size	Hardness (Durometer)
Polyurethane	+/- 0.006" (+/-0.15 mm)	Shore A 85 or higher
Polyethylene	+/- 0.004" (+/-0.1 mm)	Shore D 44—D75
Polypropylene	+/- 0.004" (+/-0.1 mm)	Shore D 44—D75
Nylon	+/- 0.004" (+/-0.1 mm)	Shore D 44—D75
Pre-grooved Metal Tubing	+/- 0.004" (+/-0.1 mm)	

E. Specifications, Materials of Construction, and Schematic of Typical Construction:

Specifications	
Operating Pressure Range	0 - 180 PSI (0 - 1200 kpa)
Vacuum	0 - 29.5" Hg (750 mm Hg)
Operating Temperature	32 - 140°F (0 - 60 °C)
Recommended Tubing Material	Polyurethane, Nylon, Polyethylene, Polypropylene
Metal Body	Brass, Nickel Plated
Plastic Body	PBT (Polybutylene terephthalate)
Release Button	POM (Poly oxy methylene copolymer)
Grip Ring or Collet	300 series Stainless Steel
O-ring	NBR (Buna-N)
Thread Sealant	Teflon
Service	FOR AIR ONLY

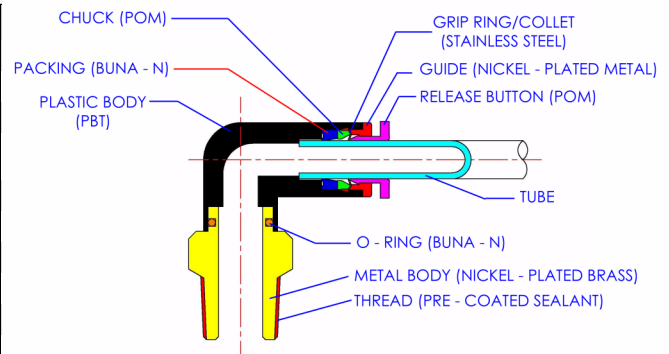

SCHEMATIC OF TYPICAL COMPOSITE FITTING CONSTRUCTION

Tel: 650-856 8833 | www.StcValve.com